

With pneumatic and electric actuators

ARI-STEVI® 470 / 471 - ANSI

Pneumatic actuator

ARI-DP 32 - 35

- Reversible pneumatic actuator
- Actuator with rolling diaphragm
- Air supply pressure max. 6 bar
- Stem protection by bellow
- Maintenance-free O-ring sealing
- Assembly of additional devices acc. to DIN IEC 60534-6

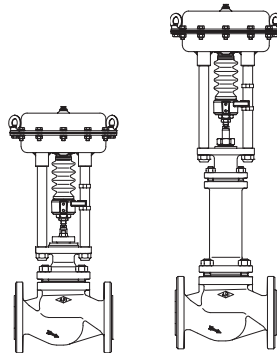

Page 4

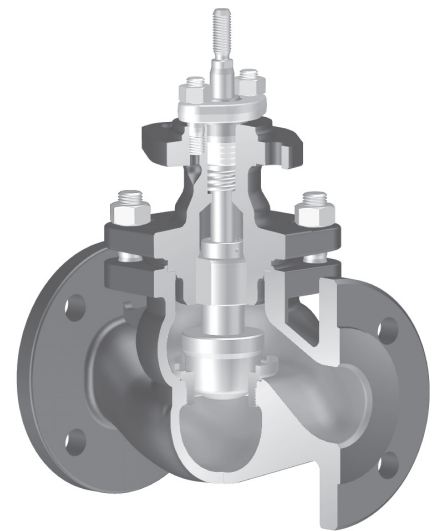

Fig. 470 - ANSI

ARI-STEVI® 470 / 471 - ANSI

Electric actuator

ARI-PREMIO 2,2 - 15 kN

ARI-PREMIO-Plus 2,2 - 15kN

- Enclosure IP 65
- 2 torque switches
- Handwheel
- Additional devices available, e.g. potentiometer

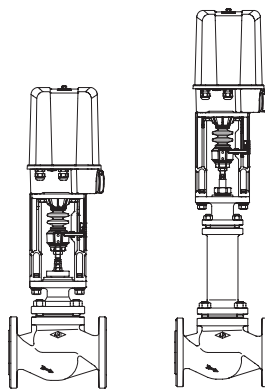

Page 12

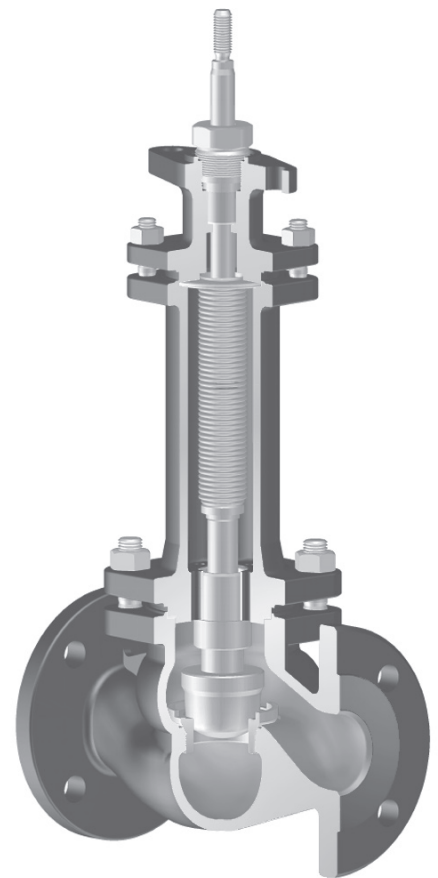

Fig. 471 - ANSI

ARI-STEVI® 470 / 471 - ANSI

Electric actuator

AUMA SAR 07.2 - 14.6

- Enclosure IP 67
- 2 torque switches
- 2 travel switches
- Handwheel
- Overheating protection for motor as standard
- Additional devices available, e.g. potentiometer
- Explosion proof version available

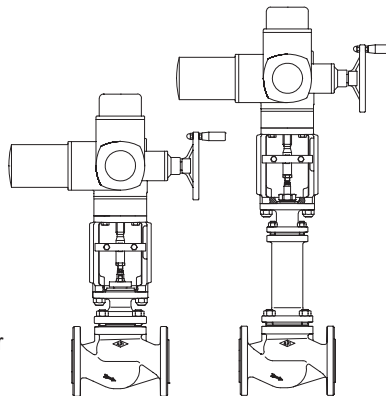

Page 14

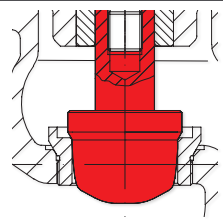
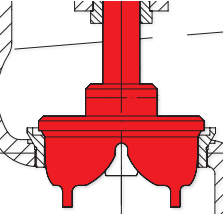
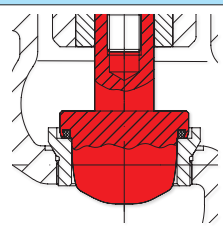
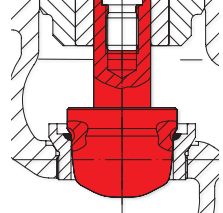
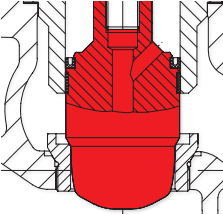
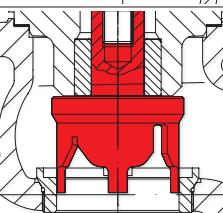

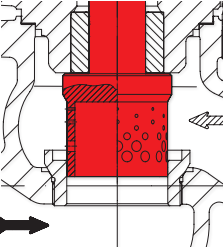

Figure	Nominal pressure	Material	Nominal diameter	Information / restriction of technical rules need to be observed!
32.470....90	ANSI150	SA 216 WCB	DN 25-200	Information / restriction of technical rules need to be observed! ARI-Valves of EN-JL1040 are not allowed to be operated in systems acc. to TRD 110. A production permission acc. to TRB 801 No. 45 is available. (Acc. to TRB 801 No. 45 EN-JL1040 is not allowed.) The engineer, designing a system or a plant, is responsible for the selection of the correct valve. Resistance and fitness must be verified, contact manufacturer for information (refer to Product overview and Resistance list).
32.471....90	ANSI150			
35.470....90	ANSI300			
35.471....90	ANSI300 (restricted pressure)			
Other materials and versions on request.				

Stem sealing				
Fig. 470	standard		optional	
	DN25- 150	DN200	DN25- 200	DN25- 200
	I. PTFE-V-ring unit -10°C to 220°C	II. PTFE-packing -10°C to 250°C	I. EPDM-sealing -10°C to 150°C (allowed for water and steam up to 180°C)	II. PTFE-packing -10°C to 250°C II. Pure graphite-packing -10°C to 450°C

Fig. 471	standard		optional	
	DN25- 200		DN25- 100	DN150-200
	III. Stainless steel-bellow with pure graphite-packing -60°C to 450°C		III. Stainless steel-bellow with V-ring unit -60°C to 220°C	III. Stainless steel-bellow with EPDM-sealing -60°C to 150°C (allowed for water and steam up to 180°C)

Pressure-temperature-ratings				Intermediate values for max. permissible operational pressures can be determined by linear interpolation of the given temperature / pressure chart.									
acc. to ANSI B16.5				-29°C to 38°C ¹⁾	50°C	100°C	150°C	200°C	250°C	300°C	350°C	400°C	425°C
Fig. 470 / 471	SA216WCB	ANSI150	(bar)	19,6	19,2	17,7	15,8	13,8	12,1	10,2	8,4	6,5	5,5
Fig. 470	SA216WCB	ANSI300	(bar)	51,1	50,1	46,6	45,1	43,8	41,9	39,8	37,6	34,7	28,8
acc. to manufacturers standard				-29°C to -10°C ¹⁾	-10°C to 120°C	150°C	200°C	250°C	300°C	350°C	400°C	425°C	
Fig. 471-ANSI300	SA216WCB	ANSI300	(bar)	30	40	38,1	35	32	28	25,7	23,8	18,5	
(restricted pressure)													

¹⁾ Valve with extended bonnet, studs and nuts made of A4-70 (at temperatures below -10°C)

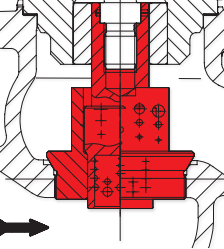
Plug design standard			Guiding	Rangeability
DN25-150 Parabolic plug, metal seat	<ul style="list-style-type: none"> - Leakage class IV acc. to ANSI / FCI 70-2 - from Kvs 0,1 - Flow characteristic: equal percentage (glp) (from Kvs 100 modified) linear (lin) (from Kvs 1) 		Plug shaft	50 : 1
DN200 V-port plug metal seat	<ul style="list-style-type: none"> - Leakage class IV acc. to ANSI / FCI 70-2 - Flow characteristic: - equal percentage (glp) (from Kvs 100 modified) - linear (lin) 		Plug shaft / Seat ring	30 : 1
Plug design optional			Guiding	Rangeability
Parabolic plug with PTFE-Soft seal (max. 200°C)	<ul style="list-style-type: none"> - Leakage class VI acc. to ANSI / FCI 70-2 - from Kvs 1,0 - Flow characteristic: - equal percentage (glp) (from Kvs 100 modified) - linear (lin) 		Plug shaft	50 : 1
Parabolic plug with armoured sealing edge	<ul style="list-style-type: none"> - Leakage class IV acc. to ANSI / FCI 70-2 - from Kvs 1,0 - Flow characteristic: - equal percentage (glp) (from Kvs 100 modified) - linear (lin) 		Plug shaft	50 : 1
Parabolic plug with Pressure balanced plug metal seat Piston seal: PTFE with stainless steel spring (max. 200°C)	<ul style="list-style-type: none"> - Leakage class IV acc. to ANSI / FCI 70-2 - from Kvs 6,3 - Flow characteristic: - equal percentage (glp) (from Kvs 100 modified) - linear (lin) 		Plug shaft	50 : 1
V-port plug metal seat	<ul style="list-style-type: none"> - Leakage class IV acc. to ANSI / FCI 70-2 - from Kvs 63 - Flow characteristic: - equal percentage (glp) (from Kvs 100 modified) - linear (lin) 		Plug shaft / Seat ring	30 : 1
Perforated plug metal seat optional: Pressure balanced perforated plug metal seat Piston seal: PTFE with stainless steel spring (max. 200°C)	<ul style="list-style-type: none"> - Leakage class IV acc. to ANSI / FCI 70-2 - from Kvs 1 - Flow characteristic: - equal percentage (glp) (from Kvs 100 modified) - linear (lin) <p>  Flow direction for gas and steam to reduce the sound level  Flow direction for liquids at critical operating conditions (cavitation / flashing) </p>		Plug shaft / Seat ring	30 : 1
Perforated plug with supporting basket metal seat	<ul style="list-style-type: none"> - Leakage class IV acc. to ANSI / FCI 70-2 - Flow characteristic: equal percentage (glp) (from Kvs 100 modified) linear (lin) - multistage pressure reduction <p>  Flow direction for gas / steam and liquids to reduce the sound level at critical operating conditions </p>		Plug shaft / Seat ring	30 : 1

Control valve in straightway form with pneumatic actuator ARI-DP

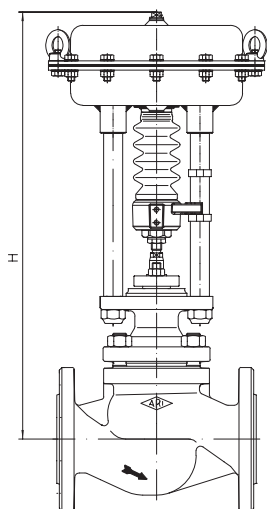

Fig. 470

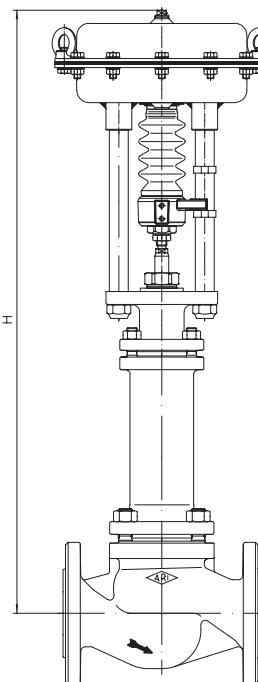
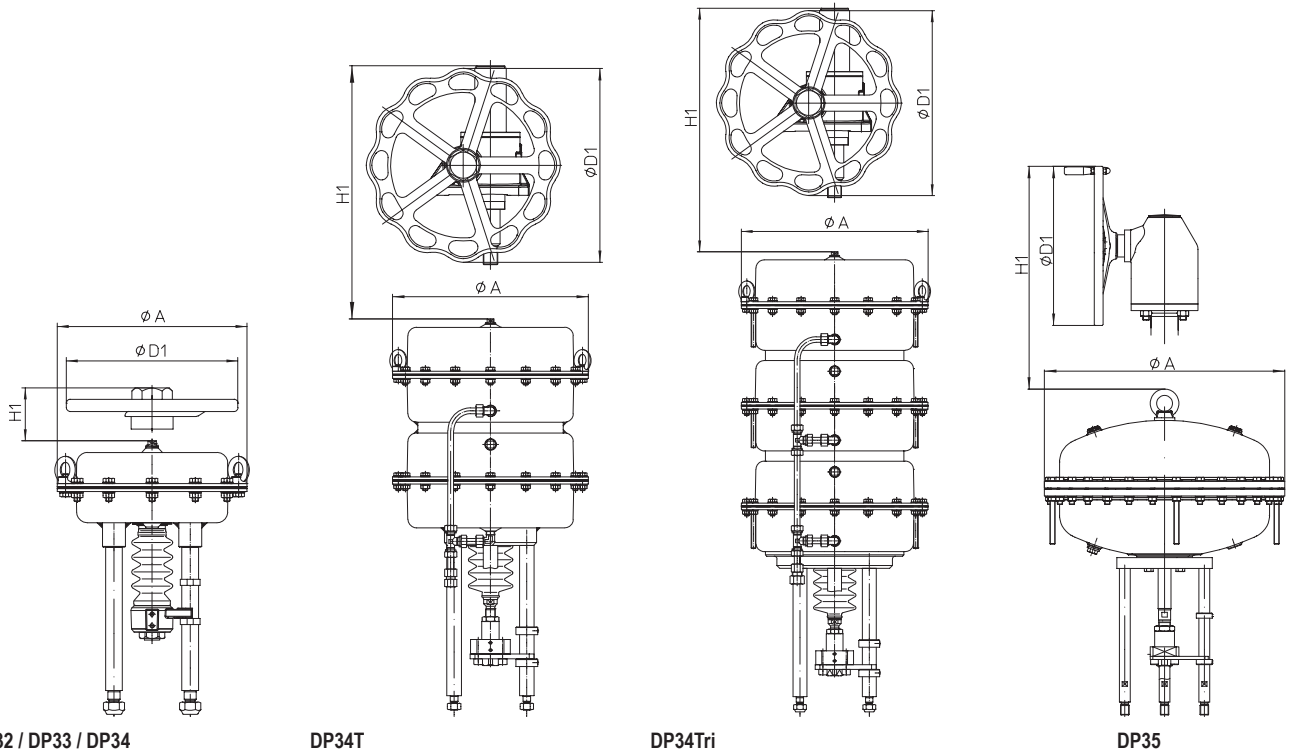

Fig. 471

Heights and weights

DN				25	40	50	80	100	150	200
Fig. 470	DP32	H	(mm)	473	504	504	522	524	584	--
		ANSI150	(kg)	18	25	27	43	61	111	--
		ANSI300	(kg)	20	28	30	50	75	136	--
	DP33	H	(mm)	528	559	559	588	590	650	--
		ANSI150	(kg)	24	31	33	49	67	117	--
		ANSI300	(kg)	26	34	36	56	81	142	--
	DP34	H	(mm)	--	694	694	723	725	785	844
		ANSI150	(kg)	--	61	63	79	97	147	248
		ANSI300	(kg)	--	64	66	86	111	172	264
	DP34T	H	(mm)	--	--	--	--	--	1051	1094
		ANSI150	(kg)	--	--	--	--	--	223	319
		ANSI300	(kg)	--	--	--	--	--	248	335
	DP34Tri	H	(mm)	--	--	--	--	--	1273	1316
		ANSI150	(kg)	--	--	--	--	--	257	353
		ANSI300	(kg)	--	--	--	--	--	282	369
DP35	H	(mm)	--	--	--	--	--	1154	1197	
	ANSI150	(kg)	--	--	--	--	--	422	518	
	ANSI300	(kg)	--	--	--	--	--	447	534	
Fig. 471	DP32	H	(mm)	630	715	715	722	752	911	--
		ANSI150	(kg)	22	26	28	45	65	114	--
		ANSI300	(kg)	23	29	31	52	73	139	--
	DP33	H	(mm)	685	770	770	788	818	977	--
		ANSI150	(kg)	28	32	34	51	71	120	--
		ANSI300	(kg)	29	35	37	58	79	145	--
	DP34	H	(mm)	--	905	905	923	953	1112	1251
		ANSI150	(kg)	--	62	64	81	101	150	233
		ANSI300	(kg)	--	65	67	88	109	175	248
	DP34T	H	(mm)	--	--	--	--	--	1573	1541
		ANSI150	(kg)	--	--	--	--	--	256	304
		ANSI300	(kg)	--	--	--	--	--	281	319
	DP34Tri	H	(mm)	--	--	--	--	--	1795	1763
		ANSI150	(kg)	--	--	--	--	--	290	338
		ANSI300	(kg)	--	--	--	--	--	315	353
	DP35	H	(mm)	--	--	--	--	--	1643	--
		ANSI150	(kg)	--	--	--	--	--	455	--
		ANSI300	(kg)	--	--	--	--	--	480	--

Further dimensions refer to pages 18-19.



DP32 / DP33 / DP34

DP34T

DP34Tri

DP35

Actuator data		DP32	DP33	DP34	DP34T	DP34Tri	DP35	
$\varnothing A$	(mm)	250	300	405		755		
Effective diaphragm area	(cm ²)	250	400	800	1600	2400	2800	
Top mounted handwheel	$\varnothing D1$	(mm)	225	300	400		500	
	H1	(mm)	270	284	442	635	635	731
	Weight	(kg)	5		17	41		49

Further technical data of the actuator: refer to data sheet ARI-DP.

max. permissible closing pressures on flow-to-open P2 = 0.
Observe pressure-temperature-limits, refer to page 2.

DN			25						40			50			80			100			150			
Parabolic plug	Kvs-value	(m³/h)	0,25 0,16 0,1	0,63 0,4	2,5 1,6 1	4	6,3	10	10	16	25	16	25	40	40	63	100	63	100	160	160			
	max. diff. pressure ¹⁾	(bar)	40						40	30	40	30	30	15	8	15	8	4	4	4	4			
V-port plug	Kvs-value	(m³/h)	--																					
	max. diff. pressure ¹⁾	(bar)	--						--			--			30			30			25	25		
Perforated plug	Kvs-value	(m³/h)	--						2,5	4	6,3	6,3	10	16	10	16	25	25	40	63	40	63	100	100
	max. diff. pressure ¹⁾	(bar)	--						40			40			40			40			40			
Seat-Ø		(mm)	3	5	12	18	22	25	25	32	40	32	40	50	50	65	80	65	80	100	100			
Travel		(mm)	20						20	30	20	30	30			30			30					
DP32 250 cm ² Spring closes on air failure  (stem extending by spring)	0,2-1,0	1,2	I. (bar)	30,6	29,2	21,2	8,1	4,8	3,3	2,5														
			II. (bar)	20	18,6	11,9	3,8	1,8	1															
			III. (bar)																					
	0,4-1,2	1,4	I. (bar)	51	51	51	25,8	16,8	12,6	11,9	6,7	3,8	6,7	3,8	2,1	2								
			II. (bar)	51	51	49,9	21,4	13,8	10,3	8,8	4,8	2,6	4,8	2,6	1,3	1,1								
			III. (bar)	9,7	9,4	8,4	7,5	7	6,5	6,5	3,6	1,8	3,6	1,8										
	0,8-2,4	2,7	I. (bar)				51	40,8	31,4	30,6	18,3	11,3	18,3	11,3	6,9	6,8	3,7	2,2	3,7	2,2	1,2	1,2		
			II. (bar)				51	37,8	29,1	27,5	16,4	10,1	16,4	10,1	6,1	5,9	3,2	1,9	3,2	1,9	1	1		
			III. (bar)	27,5	27,2	26,2	25,3	24,7	24,3	24,3	15,2	9,3	15,2	9,3	5,6	5,6	3	1,8	3	1,8				
	1,5-2,9	3,2	I. (bar)				51	51	51	38,6		38,6												
			II. (bar)				51	51	51	36,7		36,7												
			III. (bar)	40	40	40	40	40	40	40	35,5		35,5											
2,0-3,8	4,1	I. (bar)							51		51													
		II. (bar)							51		51													
		III. (bar)							40		40													

DN			25						40			50			80			100			150			
Parabolic plug	Kvs-value	(m³/h)	0,25 0,16 0,1	0,63 0,4	2,5 1,6 1	4	6,3	10	10	16	25	16	25	40	40	63	100	63	100	160	160			
	max. diff. pressure ¹⁾	(bar)	40						40	30	40	30	30	15	8	15	8	4	4	4				
V-port plug	Kvs-value	(m³/h)	--																					
	max. diff. pressure ¹⁾	(bar)	--						--			--			30			30			25	25		
Perforated plug	Kvs-value	(m³/h)	--						2,5	4	6,3	6,3	10	16	10	16	25	25	40	63	40	63	100	100
	max. diff. pressure ¹⁾	(bar)	--						40			40			40			40			40			
Seat-Ø		(mm)	3	5	12	18	22	25	25	32	40	32	40	50	50	65	80	65	80	100	100			
Travel		(mm)	20						20	30	20	30	30			30			30					
DP32 250 cm ² Spring opens on air failure  (stem retracting by spring)	1,4	I. (bar)	51	51	51	25,8	16,8	12,6	11,9	6,7	3,8	6,7	3,8	2,1	2									
		II. (bar)	51	51	49,9	21,4	13,8	10,3	8,8	4,8	2,6	4,8	2,6	1,3	1,1									
		III. (bar)	9,7	9,4	8,4	7,5	7	6,5	6,5	3,6	1,8	3,6	1,8											
	2	I. (bar)				51	51	40,7	40	24,1	15,1	24,1	15,1	9,3	9,2	5,1	3,2	5,1	3,2	1,8	1,8			
		II. (bar)				51	51	49,9	38,4	36,9	22,2	13,8	22,2	13,8	8,5	8,3	4,6	2,8	4,6	2,8	1,6	1,6		
		III. (bar)	36,3	36,1	35	34,2	33,6	33,2	33,2	21	13,1	21	13,1	8	8	4,4	2,7	4,4	2,7	1,5	1,4			
	3	I. (bar)						51	51	51	33,8	51	33,8	21,4	21,3	12,4	8	12,4	8	4,9	4,9			
		II. (bar)						51	51	51	32,6	51	32,6	20,6	20,4	11,8	7,6	11,8	7,6	4,7	4,7			
		III. (bar)	40	40	40	40	40	40	40	31,8	40	31,8	20,1	20,1	11,6	7,5	11,6	7,5	4,6	4,4				
	4	I. (bar)								51		51												
		II. (bar)								51		51												
		III. (bar)								40		40												
	5	I. (bar)												45,6	45,5	26,8	17,5	26,8	17,5	11	11			
		II. (bar)												44,8	44,6	26,2	17,2	26,2	17,2	10,8	10,8			
		III. (bar)												40	40	26,1	17	26,1	17	10,8	10,6			
	6	I. (bar)												51	51	34	22,3	34	22,3	14,1	14,1			
		II. (bar)												51	51	33,4	21,9	33,4	21,9	13,9	13,9			
		III. (bar)														33,3	21,8	33,3	21,8	13,8	13,6			

- I. Fig. 470: PTFE-V-ring unit / EPDM-sealing
 II. Fig. 470: PTFE- / pure graphite-packing
 III. Fig. 471: Bellows seal

¹⁾ max. differential pressure drop

²⁾ Air supply pressure max. to actuator: 6 bar Restriction: a) 5 bar b) 4,5 bar c) 4 bar d) 3,5 bar e) 3 bar

max. permissible closing pressures on flow-to-open P2 = 0.
Observe pressure-temperature-limits, refer to page 2.

DN			25						40			50			80			100			150		
Parabolic plug	Kvs-value	(m³/h)	0,25 0,16 0,1	0,63 0,4	2,5 1,6 1	4	6,3	10	10	16	25	16	25	40	40	63	100	63	100	160	160		
	max. diff. pressure ¹⁾	(bar)	40						40	30	40	30	30	15	8	15	8	4	4				
V-port plug	Kvs-value	(m³/h)	--						--			--			63			100	63	100	160	160	
	max. diff. pressure ¹⁾	(bar)	--						--			--			30			30	25	25			
Perforated plug	Kvs-value	(m³/h)	--			2,5	4	6,3	6,3	10	16	10	16	25	25	40	63	40	63	100	100		
	max. diff. pressure ¹⁾	(bar)	--			40			40			40			40			40			40		
Seat-Ø		(mm)	3	5	12	18	22	25	25	32	40	32	40	50	50	65	80	65	80	100	100		
Travel		(mm)	20						20	30	20	30	30			30			30				
DP33 400 cm² Spring closes on air failure (stem extending by spring)	Spring range (bar)	0,2-1,0	1,2	I. (bar)	51c)	51c)	43,7c)	18,6c)	11,9c)	8,8c)	8a)	4,3a)	2,3a)	4,3a)	2,3a)	1,1a)	1						
				II. (bar)	45,6c)	44,2c)	34,4c)	14,2c)	8,9c)	6,5c)	5a)	2,4a)	1,1a)	2,4a)	1,1a)								
				III. (bar)	6,1a)	5,8a)	4,8a)	3,9a)	3,3a)	2,9a)	2,9a)	1,2a)											
		0,4-1,2	1,4	I. (bar)		51c)	46,6c)	31c)	23,7c)	22,9a)	13,5a)	8,3a)	13,5a)	8,3a)	4,9a)	4,8	2,5	1,4	2,5	1,4			
				II. (bar)	51c)	51c)	51c)	42,3c)	28c)	21,4c)	19,9a)	11,6a)	7a)	11,6a)	7a)	4,1a)	3,9	2	1,1	2	1,1		
				III. (bar)	20,2a)	19,9a)	18,9a)	18a)	17,5a)	17a)	17a)	10,5a)	6,3a)	10,5a)	6,3a)	3,7a)	3,7	1,8	1	1,8	1		
	0,8-2,4	2,7	I. (bar)				51a)	51a)	51a)	51	32	20,2	32	20,2	12,6	12,5	7,1	4,5	7,1	4,5	2,7	2,7	
			II. (bar)				51a)	51a)	51a)	49,7	30,1	19	30,1	19	11,8	11,6	6,6	4,1	6,6	4,1	2,5	2,5	
			III. (bar)	40	40	40	40	40	40	40	28,9	18,2	28,9	18,2	11,3	11,3	6,4	4	6,4	4	2,4	2,2	
	1,5-3,0	3,3	I. (bar)									41,1			41,1	26,1	26	15,1	9,8	15,1	9,8	6,1	6,1
			II. (bar)									39,9			39,9	25,3	25,1	14,6	9,5	14,6	9,5	5,9	5,9
			III. (bar)									39,1			39,1	24,8	24,8	14,4	9,3	14,4	9,3	5,8	5,6
1,7-2,7	3,1	I. (bar)								51			51										
		II. (bar)								51	51		51										
		III. (bar)								40			40										
2,0-4,0	4,5	I. (bar)									51		51	35,7	35,6	20,9	13,6	20,9	13,6	8,5	8,5		
		II. (bar)									51		51	34,9	34,7	20,4	13,3	20,4	13,3	8,3	8,3		
		III. (bar)									40		40	34,4	34,4	20,2	13,1	20,2	13,1	8,2	8,1		

DN			25						40			50			80			100			150	
Parabolic plug	Kvs-value	(m³/h)	0,25 0,16 0,1	0,63 0,4	2,5 1,6 1	4	6,3	10	10	16	25	16	25	40	40	63	100	63	100	160	160	
	max. diff. pressure ¹⁾	(bar)	40						40	30	40	30	30	15	8	15	8	4	4			
V-port plug	Kvs-value	(m³/h)	--						--			--			63			100	63	100	160	160
	max. diff. pressure ¹⁾	(bar)	--						--			--			30			30	25	25		
Perforated plug	Kvs-value	(m³/h)	--			2,5	4	6,3	6,3	10	16	10	16	25	25	40	63	40	63	100	100	
	max. diff. pressure ¹⁾	(bar)	--			40			40			40			40			40			40	
Seat-Ø		(mm)	3	5	12	18	22	25	25	32	40	32	40	50	50	65	80	65	80	100	100	
Travel		(mm)	20						20	30	20	30	30			30			30			
DP33 400 cm² Spring opens on air failure (stem retracting by spring)	Air supply pressure min. (bar) ²⁾	1,4	I. (bar)	51d)	51d)	51d)	46,6d)	31d)	23,7d)	22,9d)	13,5d)	8,3d)	13,5d)	8,3d)	4,9d)	4,8d)	2,5d)	1,4d)	2,5d)	1,4d)		
			II. (bar)	51d)	51d)	51d)	42,3d)	28d)	21,4d)	19,9d)	11,6d)	7d)	11,6d)	7d)	4,1d)	3,9d)	2d)	1,1d)	2d)	1,1d)		
			III. (bar)	20,2d)	19,9d)	18,9d)	18d)	17,5d)	17d)	17d)	10,5d)	6,3d)	10,5d)	6,3d)	3,7d)	3,7d)	1,8d)	1d)	1,8d)	1d)		
		2	I. (bar)				51d)	51d)	51d)	51d)	41,2d)	26,2d)	41,2d)	26,2d)	16,5d)	16,4d)	9,4d)	6d)	9,4d)	6d)	3,7d)	3,7d)
			II. (bar)				51d)	51d)	51d)	51d)	39,3d)	24,9d)	39,3d)	24,9d)	15,7d)	15,5d)	8,9d)	5,7d)	8,9d)	5,7d)	3,4d)	3,4d)
			III. (bar)	40d)	40d)	40d)	40d)	40d)	40d)	40d)	38,2d)	24,2d)	38,2d)	24,2d)	15,2d)	15,2d)	8,7d)	5,5d)	8,7d)	5,5d)	3,4d)	3,2d)
		3	I. (bar)								51d)	51d)	51d)	51d)	35,7d)	35,6d)	20,9d)	13,6d)	20,9d)	13,6d)	8,5d)	8,5d)
			II. (bar)								51d)	51d)	51d)	51d)	34,9d)	34,7d)	20,4d)	13,3d)	20,4d)	13,3d)	8,3d)	8,3d)
			III. (bar)								40d)	40d)	40d)	40d)	34,4d)	34,4d)	20,2d)	13,1d)	20,2d)	13,1d)	8,2d)	8,1d)
		4	I. (bar)												51a)	51	32,4	21,2	32,4	21,2	13,4	13,4
			II. (bar)												51a)	51	31,8	20,9	31,8	20,9	13,2	13,2
			III. (bar)												40a)	40	31,6	20,7	31,6	20,7	13,1	12,9
		5	I. (bar)														43,8	28,8	43,8	28,8	18,3	18,3
			II. (bar)														43,3	28,5	43,3	28,5	18,1	18,1
			III. (bar)														40	28,4	40	28,4	18	17,8
		6	I. (bar)														51	36,4	51	36,4	23,2	23,2
			II. (bar)														51	36,1	51	36,1	23	23
			III. (bar)														36		36	22,9	22,7	

I. Fig. 470: PTFE-V-ring unit / EPDM-sealing
 II. Fig. 470: PTFE- / pure graphite-packing
 III. Fig. 471: Bellows seal

¹⁾ max. differential pressure drop

²⁾ Air supply pressure max. to actuator: 6 bar Restriction: a) 5 bar b) 4,5 bar c) 4 bar d) 3,5 bar e) 3 bar

max. permissible closing pressures on flow-to-open P2 = 0.
Observe pressure-temperature-limits, refer to page 2.

DN			40			50			80			100			150			200			
Parabolic plug	Kvs-value	(m³/h)	10	16	25	16	25	40	40	63	100	63	100	160	160	250	400	--			
	max. diff. pressure ¹⁾	(bar)	40	40	30	40	30	30	30	15	8	15	8	4	4	2	2	--			
V-port plug	Kvs-value	(m³/h)	--			--			63			63	100	160	160	250	400	250	400	630	
	max. diff. pressure ¹⁾	(bar)	--			--			30			30	25	15	25	15	15	15	15	12	
Perforated plug	Kvs-value	(m³/h)	6,3	10	16	10	16	25	25	40	63	40	63	100	100	160	250	160	250	400	
	max. diff. pressure ¹⁾	(bar)	40			40			40			40			40			40	30		
Seat-Ø		(mm)	25	32	40	32	40	50	50	65	80	65	80	100	100	125	150	125	150	200	
Travel		(mm)	20	30		20	30		30			30			30	50		50	50	65	
DP34 800 cm ² Spring closes on air failure (stem extending by spring)	0,2-1,0	1,2	I. (bar)		8,3e)		8,3e)	5e)	4,9	2,6	1,5	2,6	1,5								
			II. (bar)		7,1e)		7,1e)	4,2e)	4	2	1,1	2	1,1								
			III. (bar)		6,4e)		6,4e)	3,7e)	3,7b)	1,9b)	1b)	1,9b)	1b)								
		1,4	I. (bar)		20,4d)		20,4d)	12,7d)	12,6	7,2	4,5	7,2	4,5	2,7	2,7	1,6	1	1,6			
			II. (bar)		19,1d)		19,1d)	11,9d)	11,7	6,6	4,2	6,6	4,2	2,5	2,5	1,4		1,2			
			III. (bar)		18,4d)		18,4d)	11,4d)	11,4d)	6,5b)	4,1b)	6,5b)	4,1b)	2,4b)	2,2	1,3		1,3 a)			
	0,8-2,4	2,7	I. (bar)		44,4b)		44,4b)	28,2b)	28,1	16,4	10,6	16,4	10,6	6,6	6,6	4,1	2,7	4,1	2,7		
			II. (bar)		43,2b)		43,2b)	27,4b)	27,2	15,9	10,3	15,9	10,3	6,4	6,4	4	2,6	3,8	2,5		
			III. (bar)		40b)		40b)	26,9b)	26,9	15,7	10,2	15,7	10,2	6,3	6,2	3,8	2,5	3,8	2,5		
	1,0-2,0	2,4	I. (bar)																	1,9	
			II. (bar)																	1,8	
			III. (bar)																	1,8	
	1,5-3,0	3,3	I. (bar)													8,5	5,8	8,5	5,8		
			II. (bar)													8,4	5,7	8,2	5,6		
			III. (bar)													8,2	5,6	8,2	5,6		
	2,1-3,0	3,3	I. (bar)		51a)		51a)	51a)	51	46,4	30,5	46,4	30,5	19,4	19,4						
			II. (bar)		51a)		51a)	51a)	51	45,9	30,2	45,9	30,2	19,2	19,2						
			III. (bar)					40a)	40	40	30,1	40	30,1	19,1	18,9						
	2,0-4,0	4,5	I. (bar)													11,7	8	11,7	8	4,4	
			II. (bar)													11,5	7,9	11,3	7,8	4,3	
			III. (bar)													11,4	7,8	11,4	7,8	4,3	
	2,4-3,6	4	I. (bar)							51	35,1	51	35,1	22,4	22,4						
			II. (bar)							51	34,8	51	34,8	22,2	22,2						
			III. (bar)								34,7		34,7	22,1	21,9						

DN			40			50			80			100			150			200			
Parabolic plug	Kvs-value	(m³/h)	10	16	25	16	25	40	40	63	100	63	100	160	160	250	400				
	max. diff. pressure ¹⁾	(bar)	40	40	30	40	30	30	30	15	8	15	8	4	4	2	2				
V-port plug	Kvs-value	(m³/h)							30			30	25	15	15	15	12	250	400	630	
	max. diff. pressure ¹⁾	(bar)							30			30	25	15	15	15	12	15	15	12	
Perforated plug	Kvs-value	(m³/h)	6,3	10	16	10	16	25	25	40	63	40	63	100	100	160	250	160	250	400	
	max. diff. pressure ¹⁾	(bar)	40			40			40			40			40			40	30		
Seat-Ø		(mm)	25	32	40	32	40	50	50	65	80	65	80	100	100	125	150	125	150	200	
Travel		(mm)	20	30		20	30		30			30			30	50		50	50	65	
DP34 800 cm ² Spring opens on air failure (stem retracting by spring)	1,4	I.	(bar)		20,4e)		20,4e)	12,7e)	12,6	7,2	4,5	7,2	4,5	2,7	2,7	1,6	1	1,6	1		
			II. (bar)		19,1e)		19,1e)	11,9e)	11,7	6,6	4,2	6,6	4,2	2,5	2,5	1,4		1,2			
			III. (bar)		18,4e)		18,4e)	11,4b)	11,4e)	6,5b)	4,1b)	6,5b)	4,1b)	2,4b)	2,2	1,3		1,3a)			
		2	II.	I. (bar)		51e)		51e)	35,9	21	13,7	21	13,7	8,6	8,6	5,4	3,6	5,3	3,6	1,9	
				II. (bar)		51e)		51e)	35,2e)	35	20,5	13,4	20,5	13,4	8,4	8,4	5,2	3,5	5	3,4	1,8
				III. (bar)		40e)		40e)	34,7e)	34,7b)	20,3b)	13,2b)	20,3b)	13,2b)	8,3b)	8,1	5,1	3,4	5,1a)	3,4a)	1,8a)
	3	I.	(bar)				51e)	51	44,1	29	44,1	29	18,4	18,4	11,7	8	11,7	8	4,4		
			II. (bar)				51e)	51	43,6	28,7	43,6	28,7	18,2	18,2	11,5	7,9	11,3	7,8	4,3		
			III. (bar)				40e)	40b)	40b)	28,5b)	40b)	28,5b)	18,1b)	18	11,4	7,8	11,4a)	7,8a)	4,3a)		
	4	I.	(bar)					51	44,3	28,3	28,3	18	12,4	18	12,4	18	12,4	18	6,9		
			II. (bar)					51	44	28,1	28,1	17,9	12,3	17,7	12,2	6,7					
			III. (bar)						40b)		40b)	28b)	27,8	17,7	12,2	17,7a)	12,2a)	6,8a)			
	5	I.	(bar)					51		51	38,1	38,1	24,3	16,8	24,3	16,8	24,3	16,8	9,3		
			II. (bar)					51		51	37,9	37,9	24,2	16,7	24	16,6	24	16,6	9,2		
			III. (bar)										37,6	24	16,6	24a)	16,6a)	9,2a)			
	6	I.	(bar)								48	48	30,6	21,2	30,6	21,2	11,8				
			II. (bar)								47,7	47,7	30,5	21,1	30,3	21	11,7				
			III. (bar)										40	30,3	21						

- I. Fig. 470: PTFE-V-ring unit / EPDM-sealing
- II. Fig. 470: PTFE- / pure graphite-packing
- III. Fig. 471: Bellows seal

¹⁾ max. differential pressure drop

²⁾ Air supply pressure max. to actuator: 6 bar Restriction: a) 5 bar b) 4,5 bar c) 4 bar d) 3,5 bar e) 3 bar

max. permissible closing pressures on flow-to-open P2 = 0.
Observe pressure-temperature-limits, refer to page 2.

DN				150			200				
Parabolic plug	Kvs-value	(m ³ /h)		160	250	400	--				
	max. diff. pressure ¹⁾	(bar)		4	2		--				
V-port plug	Kvs-value	(m ³ /h)		160	250	400	250	400	630		
	max. diff. pressure ¹⁾	(bar)		25	15		15		12		
Perforated plug	Kvs-value	(m ³ /h)		100	160	250	160	250	400		
	max. diff. pressure ¹⁾	(bar)		40			40		30		
Seat-Ø		(mm)		100	125	150	125	150	200		
Travel		(mm)		30	50		50		65		
DP34T 1600 cm² Spring closes on air failure (stem extending by spring)	Spring range (bar)	Air supply pressure min. (bar) ²⁾	0,2-1,0	I.	(bar)	2,7	1,6	1	1,6		
				II.	(bar)	2,2	1,2		1,2		
				III.	(bar)	2 a)	1,1 a)		1,3 e)		
			0,4-1,2	I.	(bar)	6,6	4,1	2,7	4,1	2,7	1,4
				II.	(bar)	6,1	3,8	2,5	3,8	2,5	1,3
				III.	(bar)	6 a)	3,7 a)	2,4 a)	3,8 d)	2,5 d)	1,3 d)
			0,8-2,4	I.	(bar)	14,5	9,1	6,2	9,1	6,2	
				II.	(bar)	14	8,8	6	8,8	6	
				III.	(bar)	13,8	8,7	6	8,8 b)	6 b)	
			1,0-2,0	I.	(bar)						4,4
				II.	(bar)						4,3
				III.	(bar)						4,3 c)
			1,5-3,0	I.	(bar)		18	12,4	18	12,4	
				II.	(bar)		17,7	12,2	17,7	12,2	
				III.	(bar)		17,6	12,1	17,7 a)	12,2 a)	
			2,1-3,0	I.	(bar)	40,1					
				II.	(bar)	39,6					
				III.	(bar)	39,4					
			2,0-4,0	I.	(bar)		24,3	16,8	24,3	16,8	9,3
				II.	(bar)		24	16,6	24	16,6	9,2
				III.	(bar)		23,9	16,5	24	16,6	9,2
			2,4-3,6	I.	(bar)	46					
				II.	(bar)	45,5					
				III.	(bar)	40					

DN				150			200				
Parabolic plug	Kvs-value	(m ³ /h)		160	250	400	--				
	max. diff. pressure ¹⁾	(bar)		4	2		--				
V-port plug	Kvs-value	(m ³ /h)		160	250	400	250	400	630		
	max. diff. pressure ¹⁾	(bar)		25	15		15		12		
Perforated plug	Kvs-value	(m ³ /h)		100	160	250	160	250	400		
	max. diff. pressure ¹⁾	(bar)		40			40		30		
Seat-Ø		(mm)		100	125	150	125	150	200		
Travel		(mm)		30	50		50		65		
DP34T 1600 cm² Spring opens on air failure (stem retracting by spring)	Air supply pressure min. (bar) ²⁾	1,5	I.	(bar)	8,6	5,3	3,6	5,3	3,6	1,9	
			II.	(bar)	8,1	5	3,4	5	3,4	1,8	
			III.	(bar)	7,9 a)	4,9 a)	3,3 a)	5,1 e)	3,4 e)	1,8 e)	
			2	I.	(bar)	18,4	11,7	8	11,7	8	4,4
				II.	(bar)	17,9	11,3	7,8	11,3	7,8	4,3
				III.	(bar)	17,8 a)	11,2 a)	7,7 a)	11,4 e)	7,8 e)	4,3 e)
			3	I.	(bar)	38,1	24,3	16,8	24,3	16,8	9,3
				II.	(bar)	37,6	24	16,6	24	16,6	9,2
				III.	(bar)	37,4 a)	23,9 a)	16,5 a)	24 e)	16,6 e)	9,2 e)
			4	I.	(bar)	51	36,9	25,6	36,9	25,6	14,3
				II.	(bar)	51	36,6	25,4	36,6	25,4	14,2
				III.	(bar)	40 a)	36,5 a)	25,3 a)			
			5	I.	(bar)		49,6	34,4	49,6	34,4	19,3
				II.	(bar)		49,2	34,2	49,2	34,2	19,1
				III.	(bar)		40 a)	34,1 a)			
			6	I.	(bar)		51	43,2	51	43,2	24,2
				II.	(bar)		51	42,9	51	42,9	24,1
				III.	(bar)						

- I. Fig. 470: EPDM-sealing
- II. Fig. 470: PTFE- / pure graphite-packing
- III. Fig. 471: Bellows seal

¹⁾ max. differential pressure drop

²⁾ Air supply pressure max. to actuator: 6 bar Restriction: a) 5 bar b) 4,5 bar c) 4 bar d) 3,5 bar e) 3 bar

max. permissible closing pressures on flow-to-open P2 = 0.
Observe pressure-temperature-limits, refer to page 2.

DN				150			200					
Parabolic plug	Kvs-value	(m³/h)	160	250	400	--						
	max. diff. pressure ¹⁾	(bar)	4	2		--						
V-port plug	Kvs-value	(m³/h)	160	250	400	250	400	630				
	max. diff. pressure ¹⁾	(bar)	25	15		15		12				
Perforated plug	Kvs-value	(m³/h)	100	160	250	160	250	400				
	max. diff. pressure ¹⁾	(bar)	40			40		30				
Seat-Ø			(mm)	100	125	150	125	150	200			
Travel			(mm)	30	50		50		65			
<p>DP34Tri 2400 cm² Spring closes on air failure (stem extending by spring)</p>	Spring range (bar)	Air supply pressure min. (bar ²⁾)	1,5	I.	(bar)	4,6 a)	2,8 a)	1,9 a)	2,8 a)	1,9 a)		
				0,2-1,0	II.	(bar)	4,1 a)	2,5 a)	1,6 a)	2,5 a)	1,6 a)	
					III.	(bar)	4 d)	2,4 d)	1,6 d)	2,5 f)	1,6 f)	
			0,4-1,2		I.	(bar)	10,6 a)	6,6 a)	4,5 a)	6,6 a)	4,5 a)	2,4 a)
				II.	(bar)	10,1 a)	6,3 a)	4,3 a)	6,3 a)	4,3 a)	2,3 a)	
				III.	(bar)	9,9 c)	6,2 c)	4,2 c)	6,3 f)	4,3 f)	2,3 f)	
			0,8-2,4	I.	(bar)	22,4 a)	14,2 a)	9,8 a)	14,2 a)	9,8 a)	5,4 a)	
				II.	(bar)	21,9 a)	13,9 a)	9,5 a)	13,9 a)	9,5 a)	5,3 a)	
				III.	(bar)	21,7 a)	13,8 a)	9,5 a)	13,9 d)	9,6 d)	5,3 d)	
			1,0-2,0	I.	(bar)						6,9 a)	
				II.	(bar)						6,7 a)	
				III.	(bar)						6,8 d)	
			1,5-3,0	I.	(bar)		27,5 a)	19 a)	27,5 a)	19 a)	10,6 a)	
				II.	(bar)		27,1 a)	18,8 a)	27,1 a)	18,8 a)	10,5 a)	
				III.	(bar)		27 a)	18,7 a)	27,2 b)	18,8 b)	10,5 b)	
			2,1-3,0	I.	(bar)	51 a)						
				II.	(bar)	51 a)						
				III.	(bar)	40 a)						
			2,0-4,0	I.	(bar)		36,9 a)	25,6 a)	36,9 a)	25,6 a)	14,3 a)	
				II.	(bar)		36,6 a)	25,4 a)	36,6 a)	25,4 a)	14,2 a)	
				III.	(bar)		36,5 a)	25,3 a)				

- I. Fig. 470: EPDM-sealing
- II. Fig. 470: PTFE- / pure graphite-packing
- III. Fig. 471: Bellows seal

¹⁾ max. differential pressure drop

²⁾ Air supply pressure max. to actuator: 6 bar Restriction: a) 5 bar b) 4,5 bar c) 4 bar d) 3,5 bar e) 3 bar

max. permissible closing pressures on flow-to-open P2 = 0.
Observe pressure-temperature-limits, refer to page 2.

DN						150		200				
Parabolic plug	Kvs-value		(m ³ /h)	250	400	--						
	max. diff. pressure ¹⁾		(bar)	2		--						
V-port plug	Kvs-value		(m ³ /h)	250	400	250	400	630				
	max. diff. pressure ¹⁾		(bar)	15		15		12				
Perforated plug	Kvs-value		(m ³ /h)	160	250	160	250	400				
	max. diff. pressure ¹⁾		(bar)	40		40		30				
Seat-Ø			(mm)	125	150	125	150	200				
Travel			(mm)	50		50		65				
<p>DP35 2800 cm² Spring closes on air failure (stem extending by spring)</p>	Spring range (bar)	2,45-3,28	Air supply pressure min. (bar ²⁾	3,8	I./II.	(bar)	51	37,4	51	37,4		
					III.	(bar)	40 a)	37,3 a)				
		2,97-3,8		4,3	I./II.	(bar)		45,5		45,5		
		2,72-3,8		4,3	I./II.	(bar)						23,4

DN						150		200			
Parabolic plug	Kvs-value		(m ³ /h)	250	400	--					
	max. diff. pressure ¹⁾		(bar)	2		--					
V-port plug	Kvs-value		(m ³ /h)	250	400	250	400	630			
	max. diff. pressure ¹⁾		(bar)	15		15		12			
Perforated plug	Kvs-value		(m ³ /h)	160	250	160	250	400			
	max. diff. pressure ¹⁾		(bar)	40		40		30			
Seat-Ø			(mm)	125	150	125	150	200			
Travel			(mm)	50		50		65			
<p>DP35 2800 cm² Spring opens on air failure (stem retracting by spring)</p>	Air supply pressure min. (bar ²⁾	1,5		I./II.	(bar)	12,7 b)	8,7 b)	12,7 b)	8,7 b)	4,1 b)	
				III.	(bar)	12,6 e)	8,6 e)				
		2		I./II.	(bar)	23,9 b)	16,6 b)	23,9 b)	16,6 b)	8,5 b)	
				III.	(bar)	23,8 e)	16,5 e)				
		3		I./II.	(bar)	46,5 b)	32,2 b)	46,5 b)	32,2 b)	17,3 b)	
				III.	(bar)	40 e)	32,2 e)				
4		I./II.	(bar)	51 b)	47,9)	51 b)	47,9 b)	26,2 b)			
4,5		I./II.	(bar)		51 b)		51 b)	30,6 b)			

- I. Fig. 470: EPDM-sealing
 II. Fig. 470: PTFE- / pure graphite-packing
 III. Fig. 471: Bellows seal

¹⁾ max. differential pressure drop

²⁾ Air supply pressure max. to actuator: 6 bar Restriction: a) 5 bar b) 4,5 bar c) 4 bar d) 3,5 bar e) 3 bar

Control valve in straightway form with electric actuator ARI-PREMIO / PREMIO-Plus

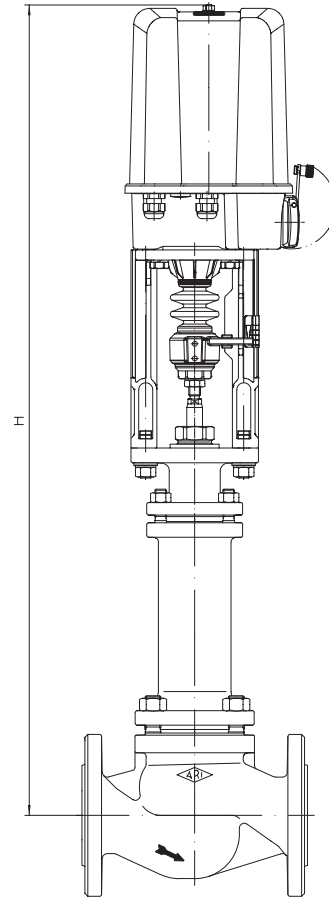
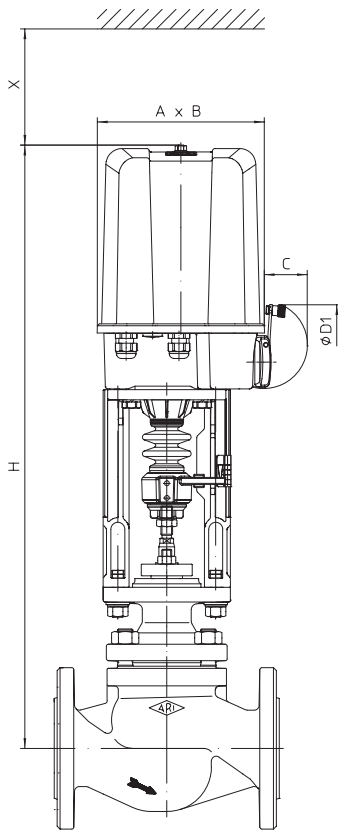

Fig. 470....90

Fig. 471....90

Actuator data		2,2 - 5 kN	12 - 15 kN
A	(mm)	171	202
B	(mm)	156	176
C	(mm)	50	97
Ø D1	(mm)	90	130
X	(mm)	150	200

Motor voltage: 230V 50Hz
Other voltages: 24V 50/60Hz; 115V 50/60Hz; 230V 60Hz
Further technical data of the actuator: refer to data sheet ARI-PREMIO/PREMIO-Plus

Heights and weights

DN			25	40	50	80	100	150	200		
Fig. 470	2,2 kN	H	(mm)	581	612	612	641	643	736	--	
		ANSI150	(kg)	15	21	23	39	58	108	--	
		ANSI300	(kg)	16	24	26	46	72	133	--	
	5 kN	H	(mm)	581	612	612	641	643	736	--	
		ANSI150	(kg)	16	22	24	40	59	109	--	
		ANSI300	(kg)	17	25	27	47	73	134	--	
	12 kN	H	(mm)	--	787	787	816	818	878	--	
		15 kN	ANSI150	(kg)	--	26	28	44	63	113	--
			ANSI300	(kg)	--	29	31	51	77	138	--
Fig. 471	2,2 kN	H	(mm)	738	823	823	841	871	1063	--	
		ANSI150	(kg)	18	23	25	41	62	111	--	
		ANSI300	(kg)	19	26	28	48	70	136	--	
	5 kN	H	(mm)	738	823	823	841	871	1063	1276	
		ANSI150	(kg)	19	24	26	42	63	112	196	
		ANSI300	(kg)	20	27	29	49	71	137	211	
	12 kN	H	(mm)	--	998	998	1016	1046	1205	1433	
		15 kN	ANSI150	(kg)	--	28	30	46	67	116	200
			ANSI300	(kg)	--	31	33	53	75	141	215

Further dimensions refer to pages 18-19.

max. permissible closing pressures on flow-to-open P2 = 0.
Observe pressure-temperature-limits, refer to page 2.

DN			25							40			50			80			100			150			200				
Parabolic plug	Kvs-value	(m³/h)	0,25 0,16 0,1	0,63 0,4	2,5 1,6 1	4	6,3	10	10	16	25	16	25	40	40	63	100	63	100	160	160	250	400	--					
	max. diff. pressure ¹⁾	(bar)	40							40	30	40	30	30	15	8	15	8	4	4	2	--							
V-port plug	Kvs-value	(m³/h)	--							--			--			63	100	63	100	160	160	250	400	250	400	630			
	max. diff. pressure ¹⁾	(bar)	--							--			--			30	30	25	25	15	15	15	12						
Perforated plug	Kvs-value	(m³/h)	--			2,5 1,6 1	4	6,3	6,3	10	16	10	16	25	25	40	63	40	63	100	100	160	250	160	250	400			
	max. diff. pressure ¹⁾	(bar)	--			40			40			40			40			40			40			40	30				
Seat-Ø		(mm)	3	5	12	18	22	25	25	32	40	32	40	50	50	65	80	65	80	100	100	125	150	125	150	200			
Travel		(mm)	20							20	30	20	30	30			30			30	50	50	50	65					
2,2 kN	Closing pressure	I. (bar)	51	51	51	51	46,7	35,9	35,2	21,1	13,2	21,1	13,2	8,1	8	4,4	2,7	4,4	2,7	1,5	1,5								
		II. (bar)	51	51	51	51	43,7	33,7	32,1	19,2	11,9	19,2	11,9	7,3	7,1	3,9	2,3	3,9	2,3	1,3	1,3								
		III. (bar)	31,8	31,5	30,5	29,6	29,1	28,6	28,6	18	11,2	18	11,2	6,8	6,8	3,7	2,2	3,7	2,2	1,2	1								
	Operating time (50 Hz)	(s)	53							53	79	53	79	79			79			79									
	Operating speed	(mm/s)	0,38																										
5 kN	Closing pressure	I. (bar)					51	51	51	51	34,6	51	34,6	21,9	21,8	12,6	8,2	12,6	8,2	5	5	3,1	2	3,1	2	1			
		II. (bar)					51	51	51	51	33,4	51	33,4	21,1	20,9	12,1	7,8	12,1	7,8	4,8	4,8	2,9	1,9	2,7	1,8				
		III. (bar)	40	40	40	40	40	40	40	40	32,6	40	32,6	20,6	20,6	11,9	7,7	11,9	7,7	4,7	4,5	2,8	1,8	2,8	1,8				
	Operating time (50 Hz)	(s)	53							53	79	53	79	79			79			79	132	132							
	Operating speed	(mm/s)	0,38																										
12 kN	Closing pressure	I. (bar)									51		51	51	51	33,2	21,8	33,2	21,8	13,8	13,8	8,7	5,9	8,7	5,9	3,2			
		II. (bar)									51		51	51	51	32,7	21,5	32,7	21,5	13,6	13,6	8,6	5,8	8,4	5,7	3,1			
		III. (bar)									40		40	40	40	32,5	21,3	32,5	21,3	13,5	13,3	8,4	5,7	8,4	5,7	3,1			
	Operating time (50 Hz)	(s)									79		79	79			79			79	132	132	171						
	Operating speed	(mm/s)									0,38	0,38																	
15 kN	Closing pressure	I. (bar)														42,1	27,7	42,1	27,7	17,6	17,6	11,1	7,6	11,1	7,6	4,2			
		II. (bar)														41,5	27,3	41,5	27,3	17,3	17,3	11	7,5	10,8	7,4	4			
		III. (bar)														40	27,2	40	27,2	17,3	17,1	10,8	7,4	10,8	7,4	4,1			
	Operating time (50 Hz)	(s)														79	79			79	132	132	171						
	Operating speed	(mm/s)	0,38																										

I. Fig. 470: PTFE-V-ring unit / EPDM-sealing
 II. Fig. 470: PTFE- / pure graphite-packing
 III. Fig. 471: Bellows seal

¹⁾ max. differential pressure drop

Control valve in straightway form with electric actuator AUMA

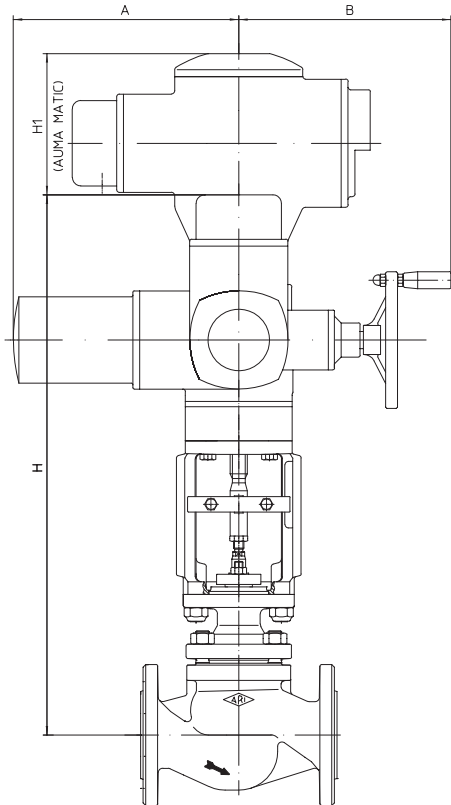

Fig. 470

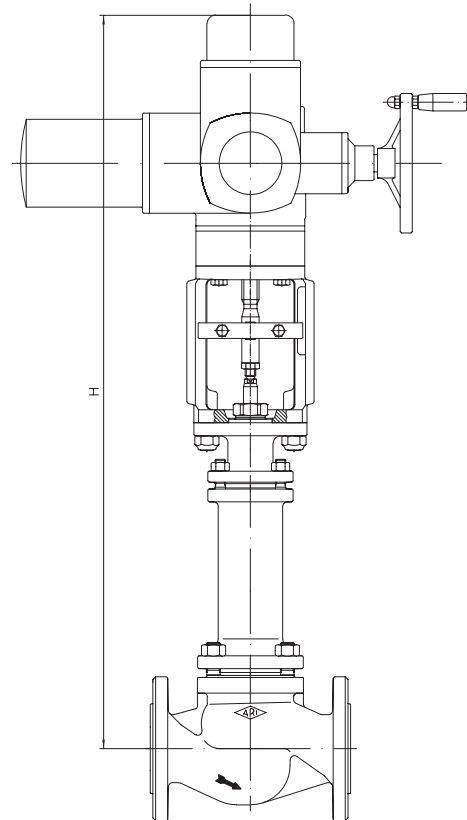

Fig. 471

Actuator data		SAR 07.2	SAR 07.6	SAR 10.2	SAR 14.2	SAR 14.6
A	(mm)	265		283	389	
B	(mm)	249		254	336	339
H1 (AUMA MATIC)	(mm)	130			182	
Motor voltage: 400V 50Hz 3~ (Other voltages on request)						
Technical data for actuator refer to price list.						

Heights and weights

DN				25	40	50	80	100	150	200
Fig. 470	SAR 07.2 SAR 07.6	H	(mm)	652	683	683	712	714	774	869
		ANSI150	(kg)	37	45	47	63	81	131	236
		ANSI300	(kg)	38	48	50	70	95	156	252
	SAR 10.2	H	(mm)	--	--	--	714	716	776	871
		ANSI150	(kg)	--	--	--	65	84	134	235
		ANSI300	(kg)	--	--	--	72	98	159	251
	SAR 14.2	H	(mm)	--	--	--	--	--	901	944
		ANSI150	(kg)	--	--	--	--	--	174	270
		ANSI300	(kg)	--	--	--	--	--	199	286
	SAR 14.6 LE100	H	(mm)	--	--	--	--	--	1159	1202
		ANSI150	(kg)	--	--	--	--	--	219	315
		ANSI300	(kg)	--	--	--	--	--	244	331
Fig. 471	SAR 07.2 SAR 07.6	H	(mm)	809	894	894	912	942	1101	1314
		ANSI150	(kg)	40	45	48	65	85	134	222
		ANSI300	(kg)	41	48	50	70	95	156	252
	SAR 10.2	H	(mm)	--	--	--	914	944	1103	1316
		ANSI150	(kg)	--	--	--	67	88	137	225
		ANSI300	(kg)	--	--	--	74	96	159	240
	SAR 14.2	H	(mm)	--	--	--	--	--	1428	--
		ANSI150	(kg)	--	--	--	--	--	207	--
		ANSI300	(kg)	--	--	--	--	--	232	--

For version with AUMA SAR Ex other heights.

Further dimensions refer to pages 18-19.

Fig. 470			DN	25	40			50			80			100			150			200			
Parabolic plug	Kvs-value	(m³/h)	10	10	16	25	16	25	40	40	63	100	63	100	160	160	250	400	--				
	max. diff. pressure ¹⁾	(bar)	40	40			30			30			15			8			4				
V-port plug	Kvs-value	(m³/h)	--	--			--			63			100			160			250				
	max. diff. pressure ¹⁾	(bar)	--	--			--			30			30			25			15				
Perforated plug	Kvs-value	(m³/h)	6,3	6,3	10	16	10	16	25	25	40	63	40	63	100	100	160	250	160	250	400		
	max. diff. pressure ¹⁾	(bar)	40	40			40			40			40			40			40				
Seat-Ø			(mm)	25	25	32	40	32	40	50	50	65	80	65	80	100	100	125	150	125	150	200	
Travel			(mm)	20	20		30	20	30		30			30			30			50			
SAR 07.2 Output drive Form A TR 20 x 4 - LH	Closing pressure	I./II.	shut off	(bar)	51	51			51	51	51	46,4	30,6	46,4	30,6	19,4							
			controlling ²⁾	(bar)	51	51			37,6	37,4	21,9	14,3	21,9	14,3	9								
	Torque			(Nm)	15	15			15	20	20	30			30								
	Operating time (50 Hz)			(s)	54	54	56	54	56	56			56										
	Output drive			(rpm)	5,6	5,6	8	5,6	8	8			8										
SAR 07.6 Output drive Form A TR 26 x 5 - LH	Closing pressure	I./II.	shut off	(bar)					51	51	43,1	51	43,1	27,5	27,5	17,5	12	17,3	11,9	6,6			
			controlling ²⁾	(bar)					51	51	31,3	20,6	31,3	20,6	13	13	8,2	5,6	8	5,5	2,9		
	Torque			(Nm)					30	30	50	60	50	60			60			60			
	Operating time (50 Hz)			(s)					64	64			64			64	55			55	71		
	Output drive			(rpm)					5,6	5,6			5,6			5,6	11			11			
SAR 10.2 Output drive Form A TR 26 x 5 - LH	Closing pressure	I./II.	shut off	(bar)					51	51	51	51	46,7	46,7	29,8	20,7	35,8	24,8	13,9				
			controlling ²⁾	(bar)					51	51	43,1	51	43,1	27,5	27,5	17,5	12	17,3	11,9	6,6			
	Torque			(Nm)					60	80	60	80	100	100			120						
	Operating time (50 Hz)			(s)					64	64			64			64	55			55	71		
	Output drive			(rpm)					5,6	5,6			5,6			5,6	11			11			
SAR 14.2 Output drive Form A TR 30 x 6 - LH	Closing pressure	I./II.	shut off	(bar)									51	51	42,7	51	42,7	24					
			controlling ²⁾	(bar)									45,2	28,9	20	28,9	20	11,1					
	Torque			(Nm)									150	225	250	225	250						
	Operating time (50 Hz)			(s)									38	63			63	59					
	Output drive			(rpm)									8			8	11						
SAR 14.6 with LE100.1 Output drive Form A TR 40 x 7 - LH	Closing pressure	I./II.	shut off	(bar)									51				51	31,7					
			controlling ²⁾	(bar)									51				40	27,7	40	27,7	15,5		
	Torque			(Nm)									250			300	400	300	400	400			
	Operating time (50 Hz)			(s)									46	54			54	51					
	Output drive			(rpm)									5,6			8	8			11			

I. Fig. 470: PTFE-V-ring unit / EPDM-sealing

II. Fig. 470: PTFE- / pure graphite-packing

¹⁾ max. differential pressure drop

²⁾ Restrictions through max. permissible torque of the actuator at controlling operation.

Fig. 471		DN	25	40			50			80			100			150			200						
Parabolic plug	Kvs-value	(m³/h)	10	10	16	25	16	25	40	40	63	100	63	100	160	160	250	400	--						
	max. diff. pressure ¹⁾	(bar)	40	40			40	30			30	15	8	15	8	4	4	2			--				
V-port plug	Kvs-value	(m³/h)	--	--			--			--			63	100	63	100	160	160	250	400	250	400	630		
	max. diff. pressure ¹⁾	(bar)	--	--			--			--			30			30			25	25	15			15	12
Perforated plug	Kvs-value	(m³/h)	6,3	6,3	10	16	10	16	25	25	40	63	40	63	100	100	160	250	160	250	160	250	400		
	max. diff. pressure ¹⁾	(bar)	40	40			40			40			40			40			40			40	30		
Seat-Ø		(mm)	25	25	32	40	32	40	50	50	65	80	65	80	100	100	125	150	125	150	125	150	200		
Travel		(mm)	20	20		30	20	30			30			30			30	50			50	50	65		
SAR 07.2 Output drive Form A TR 20 x 4 - LH	Closing pressure	III.	shut off	(bar)	40	40			40	40	40	30,4	40	30,4	19,4										
			controlling ²⁾	(bar)	40	40			40	37,1	37,1	21,7	14,2	21,7	14,2	8,9									
	Torque		(Nm)	15	15			15	20	20	30			30											
	Operating time (50 Hz)		(s)	54	54	56	54	56			56			56											
	Output drive		(rpm)	5,6	5,6	8	5,6	8			8			8											
SAR 07.6 Output drive Form A TR 26 x 5 - LH	Closing pressure	III.	shut off	(bar)						40	40			40	27,4	27,2	17,3	11,9	17,3	11,9	6,6				
			controlling ²⁾	(bar)						40	40	31,2	20,4	31,2	20,4	12,9	12,7	8	5,5	8	5,5	3			
	Torque		(Nm)						30	30	40	60	40	60			60			60					
	Operating time (50 Hz)		(s)						64	64			64			64	55			55	71				
	Output drive		(rpm)						5,6	5,6			5,6			5,6	11			11					
SAR 10.2 Output drive Form A TR 26 x 5 - LH	Closing pressure	III.	shut off	(bar)							40	40	32,2	40	29,7	20,5	26,6	18,4	10,2						
			controlling ²⁾	(bar)							40	40	27,4	27,2	17,3	11,9	17,3	11,9	6,6						
	Torque		(Nm)							60	60	70	90	100			90								
	Operating time (50 Hz)		(s)							64	64			64	55			55	71						
	Output drive		(rpm)								5,6	5,6			5,6	11			11						
SAR 14.2 Output drive Form A TR 30 x 6 - LH	Closing pressure	III.	shut off	(bar)											40	33,9									
			controlling ²⁾	(bar)												40	28,8	19,9							
	Torque		(Nm)												120	175	200								
	Operating time (50 Hz)		(s)												38	63									
	Output drive		(rpm)													8									

III. Fig. 471: Bellows seal

¹⁾ max. differential pressure drop

²⁾ Restrictions through max. permissible torque of the actuator at controlling operation.

Control valve in straightway form

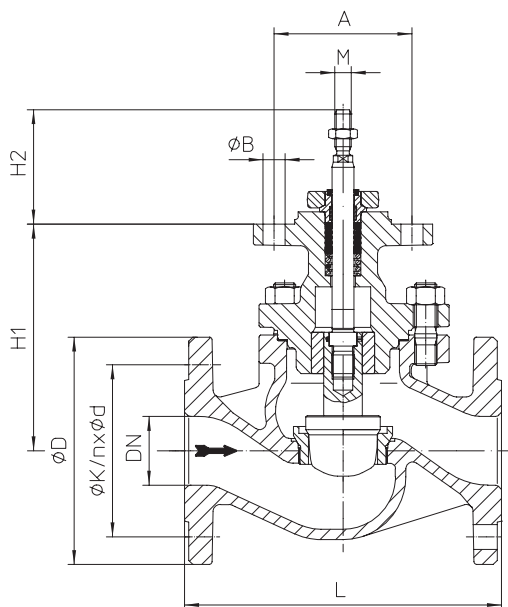
Fig. 470...90
DN25-150

(e.g.: DP32-34; PREMIO 2,2-15kN; AUMA 07.2-10.2)

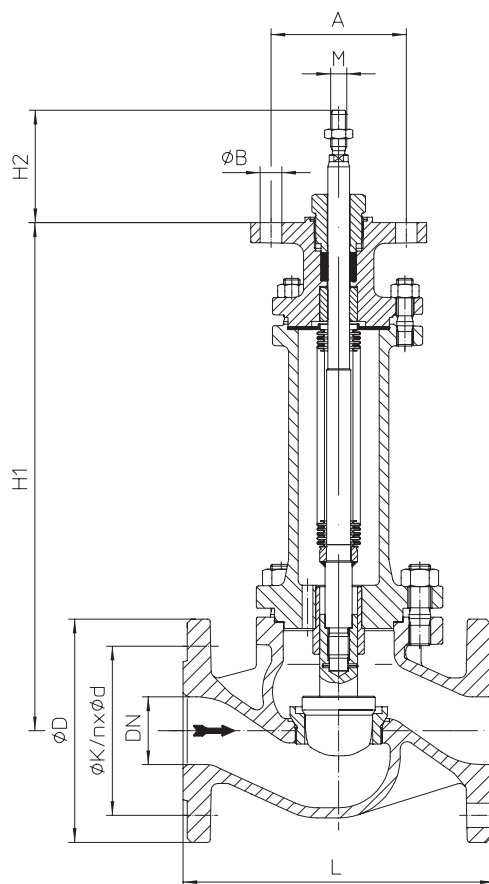
Fig. 471...90
DN25-150

(e.g.: DP32-34; PREMIO 2,2-15kN; AUMA 07.2-10.2)

DN	25	40	50	80	100	150
----	----	----	----	----	-----	-----

Dimensions			25	40	50	80	100	150
M	Fig. 470	(mm)	M10	M12		M16 x 1,5		
	Fig. 471	(mm)		M12		M14 x 1,5		M16 x 1,5
H1	Fig. 470	(mm)	134	165	165	194	196	256
	Fig. 471	(mm)	291	376	376	394	424	583
H2	Fig. 470 / Fig. 471	(mm)	83					
A	Fig. 470 / Fig. 471	(mm)	100					
ØB	Fig. 470 / Fig. 471	(mm)	2 x 16					

Face-to-face dimension Form RF acc. to ANSI / ISA - S75.03-1992 (Face-to-face dimension for Form RTJ refer to page 21.)			25	40	50	80	100	150
L	ANSI150	(mm)	184	222	254	298	352	451
	ANSI300	(mm)	197	235	267	318	368	473

Flanges acc. to ANSI B16.5			25	40	50	80	100	150
ØD	ANSI150	(mm)	110	125	150	190	230	280
	ANSI300	(mm)	124	155	165	210	254	318
ØK	ANSI150	(mm)	79	98	121	152	191	241
	ANSI300	(mm)	89	114	127	168	200	270
n x Ød	ANSI150	(mm)	4 x 16	4 x 16	4 x 19	4 x 19	8 x 19	8 x 22
	ANSI300	(mm)	4 x 19	4 x 22	8 x 19	8 x 22	8 x 22	12 x 22

Weights			25	40	50	80	100	150
Fig. 470	ANSI150	(kg)	9	16	18	34	52	102
	ANSI300	(kg)	11	19	21	41	66	127
Fig. 471	ANSI150	(kg)	13	17	19	36	56	105
	ANSI300	(kg)	14	20	22	43	64	130

max. permissible thrust			25	40	50	80	100	150
Fig. 470	(kN)		12,7	18,2		40,6		
Fig. 471	(kN)			18,2		29,6		40,6

Control valve in straightway form

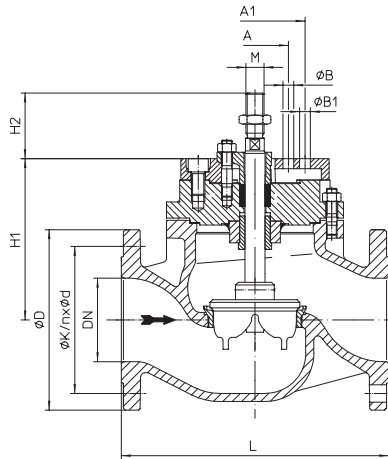

Fig. 470...90
DN200
 (e.g.: DP34, PREMIO 5-15kN)

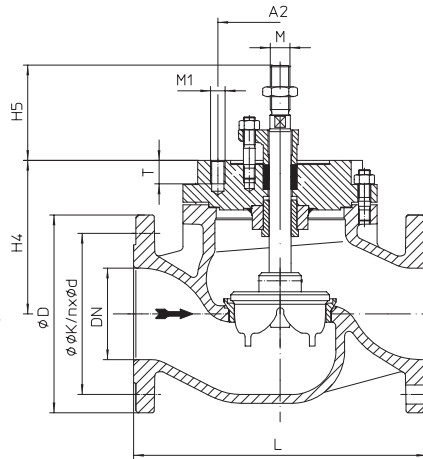

Fig. 470...90
DN200
 (e.g.: AUMA 07.6-10.2)

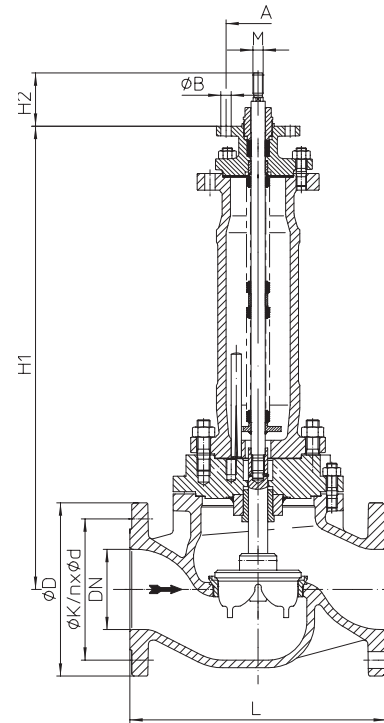

Fig. 471...90
DN200 M16
 (e.g.: PREMIO 5-15kN, AUMA 07.6-10.2)

DN	200
-----------	------------

Dimensions			
M	Fig. 470		M20
	Fig. 471	(mm)	M16 M20
H1	Fig. 470	(mm)	315
	Fig. 471	(mm)	796 722
H2	Fig. 470	(mm)	98
	Fig. 471	(mm)	83 98
H4	Fig. 470	(mm)	283
H5	Fig. 470	(mm)	130
A	Fig. 470 / Fig. 471	(mm)	100
ØB	Fig. 470	(mm)	2 x 16
A1	Fig. 470 / Fig. 471	(mm)	150
ØB1	Fig. 470 / Fig. 471	(mm)	4 x 16
A2	Fig. 470	(mm)	170
M1	Fig. 470	(mm)	M20
T	Fig. 470	(mm)	32

Face-to-face dimension Form RF acc. to ANSI / ISA - S75.03-1992			
L	ANSI150	(mm)	543
	ANSI300	(mm)	568

Flanges acc. to ANSI B16.5			
ØD	ANSI150	(mm)	345
	ANSI300	(mm)	381
ØK	ANSI150	(mm)	298
	ANSI300	(mm)	330
n x Ød	ANSI150	(mm)	8 x 22
	ANSI300	(mm)	12 x 25

Weights			
Fig. 470	ANSI150	(kg)	203
	ANSI300	(kg)	219
Fig. 471	ANSI150	(kg)	189 188
	ANSI300	(kg)	205 203

max. permissible thrust			
Fig. 470		(kN)	59,1
Fig. 471		(kN)	34

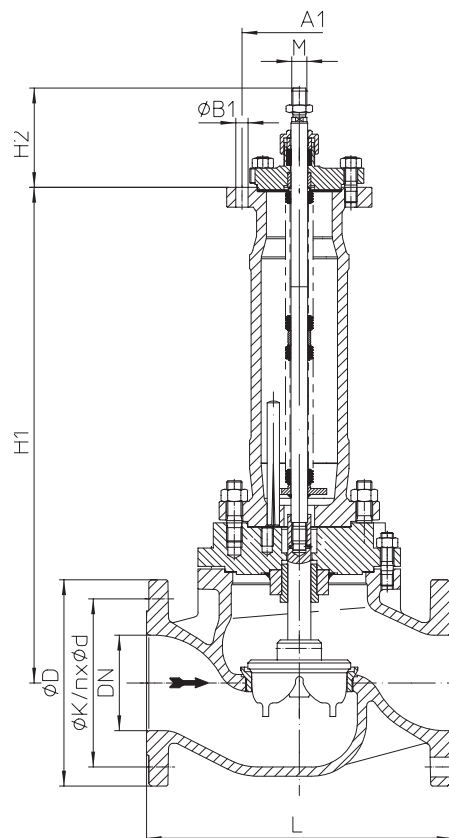

Fig. 471...90
DN200 M20
 (e.g.: DP34-34Tri)

Control valve in straightway form

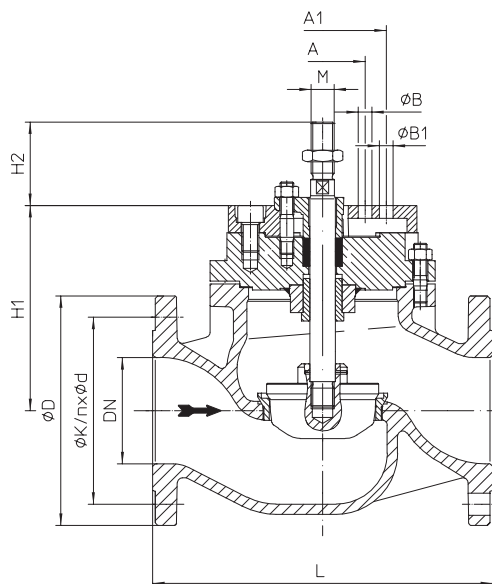

Fig. 470...90
DN150-200
 (e.g.: DP34T-34Tri)

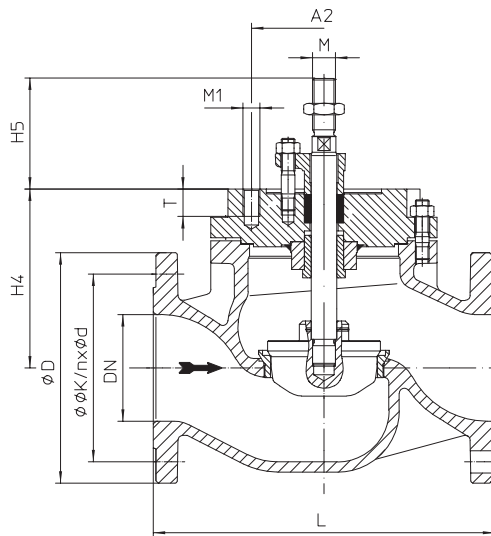

Fig. 470...90
DN150-200
 (e.g.: DP35; AUMA 14.2-14.6)

DN	150	200
----	-----	-----

Dimensions				
M	Fig. 470		M27	
	Fig. 471	(mm)	M27	--
H1	Fig. 470	(mm)	278	315
	Fig. 471	(mm)	722	--
H2	Fig. 470	(mm)	98	
	Fig. 471	(mm)	185	--
H4	Fig. 470	(mm)	240	283
H5	Fig. 470	(mm)	130	
A	Fig. 470	(mm)	100	
ØB	Fig. 470	(mm)	16	
A1	Fig. 470	(mm)	150	
	Fig. 471	(mm)	150	--
ØB1	Fig. 470	(mm)	16	
	Fig. 471	(mm)	16	--
A2	Fig. 470	(mm)	170	
M1	Fig. 470	(mm)	M20	
T	Fig. 470	(mm)	32	

Face-to-face dimension Form RF acc. to ANSI / ISA - S75.03-1992				
L	ANSI150	(mm)	451	543
	ANSI300	(mm)	473	568

Flanges acc. to ANSI B16.5				
ØD	ANSI150	(mm)	280	345
	ANSI300	(mm)	318	381
ØK	ANSI150	(mm)	241	299
	ANSI300	(mm)	270	330
n x Ød	ANSI150	(mm)	8 x 22	8 x 22
	ANSI300	(mm)	12 x 22	12 x 26

Weights				
Fig. 470	ANSI150	(kg)	107	203
	ANSI300	(kg)	132	219
Fig. 471	ANSI150	(kg)	188	--
	ANSI300	(kg)	203	--

max. permissible thrust				
Fig. 470		(kN)	112	
Fig. 471		(kN)	70	

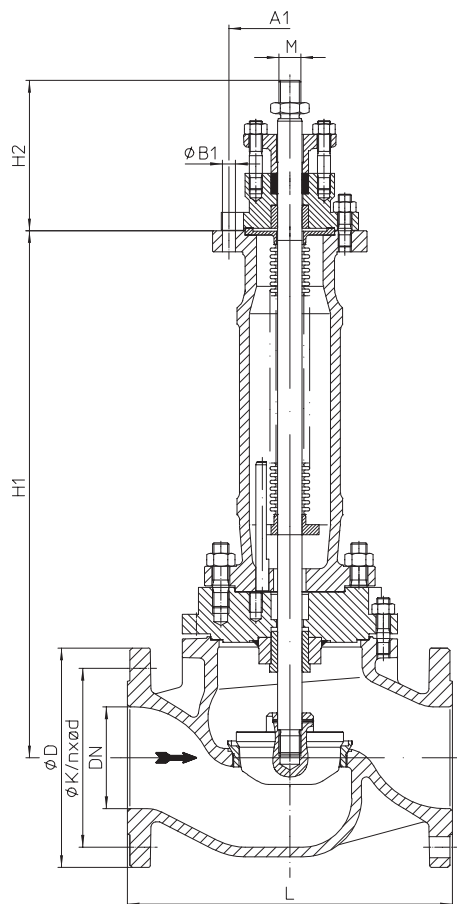
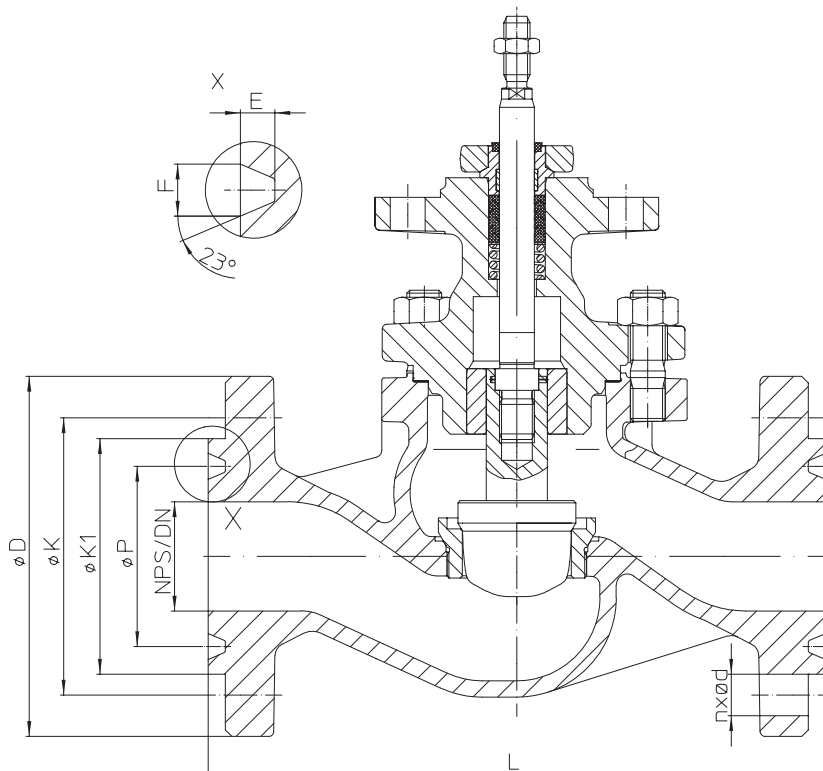

Fig. 471...90
DN150
 (e.g.: DP34T-35; AUMA 14.2)



DN	25	40	50	80	100	150	200
----	----	----	----	----	-----	-----	-----

Face-to-face dimension Form RTJ

L	ANSI150	(mm)	197	235	267	311	365	464	556
	ANSI300	(mm)	210	248	283	334	384	489	584

Flanges acc. to ANSI B16.5 (Ring-Joint Facing)

øP	ANSI150	(mm)	47,6	65,1	82,6	114	149	194	248
	ANSI300	(mm)	50,8	68,3	82,6	124	149	211	270
E	ANSI150	(mm)	6,4	6,4	6,4	6,4	6,4	6,4	6,4
	ANSI300	(mm)	6,4	6,4	7,9	7,9	7,9	7,9	7,9
F	ANSI150	(mm)	8,7	8,7	8,7	8,7	8,7	8,7	8,7
	ANSI300	(mm)	8,7	8,7	11,9	11,9	11,9	11,9	11,9
ø K1	ANSI150	(mm)	63,5	82,5	102	133	171	219	273
	ANSI300	(mm)	70	90,5	108	146	175	241	302
øD	ANSI150	(mm)	110	125	150	190	230	280	345
	ANSI300	(mm)	124	155	165	210	254	318	381
øK	ANSI150	(mm)	79	98	121	152	191	241	299
	ANSI300	(mm)	89	114	127	168	200	270	330
n x ød	ANSI150	(n x mm)	4 x 16	4 x 16	4 x 19	4 x 19	8 x 19	8 x 22	8 x 22
	ANSI300	(n x mm)	4 x 19	4 x 22	8 x 19	8 x 22	8 x 22	12 x 22	12 x 26

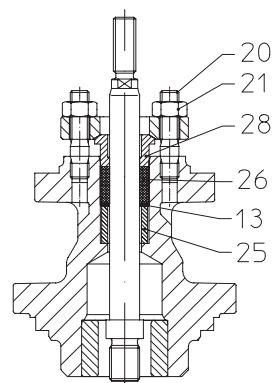
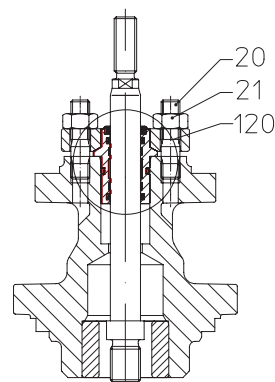
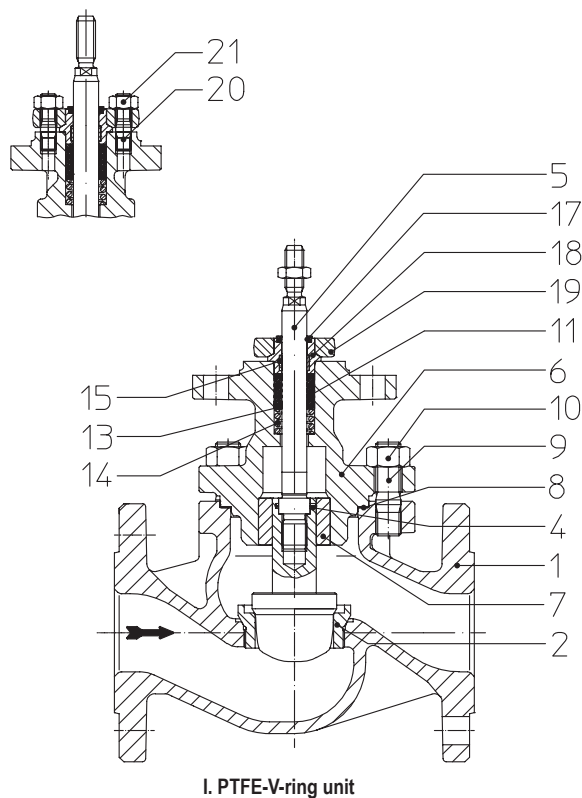

Pos.	Sp.p.	Description	Fig. 32.470...90 / Fig. 35.470...90
1		Body	SA 216 WCB
2	x	Seat ring	SA 276 Gr.420
3	x	Plug	SA 276 Gr.420
4	x	Clamping sleeve	A2
5	x	Spindle	SA 276 Gr.420
6		Mounting bonnet	SA 216 WCB
7		Guide bushing	SA 276 Gr.420 (hardened)
8	x	Gasket	Pure graphite (CrNi laminated with graphite)
9		Stud	SA 193 B7
10		Hexagon nuts	SA 194 2H
11	Set: refer to Pos. 100	V-ring unit	PTFE
13		Washer	SA 240 Gr. 304
14		Compression spring	AISI 301 A313 Gr.301
15		Guide bush	PTFE25%C
17		Scraper	PTFE
18		Stem guiding	AISI 303
19		Packing box flange	SA 105
20		Stud	A4-70
21		Hexagon nuts	A4
25	x	Distance bush	SA 276 Gr.420
26	x	Packing ring	PTFE or Pure graphite
28	x	Packing follower	SA 276 Gr.420

Stem sealings Fig. 470...90			
100	x	V-ring unit (set)	Set of: Pos. 11, 13, 14, 15, 17, 18
120	x	EPDM-sealing, cpl.	EPDM / AISI303
26	x	Packing ring	PTFE / SA276Gr.420
26	x	Packing ring	Pure graphite / SA276Gr.420
		L Spare parts	

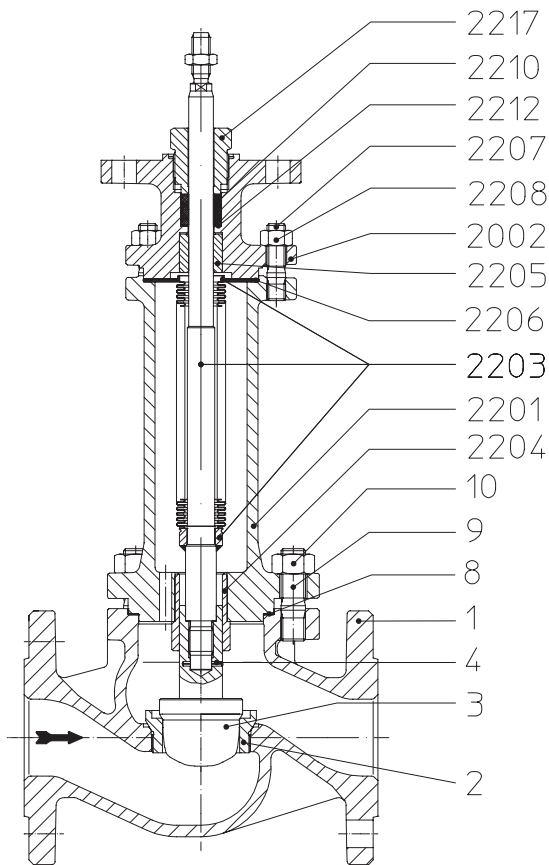
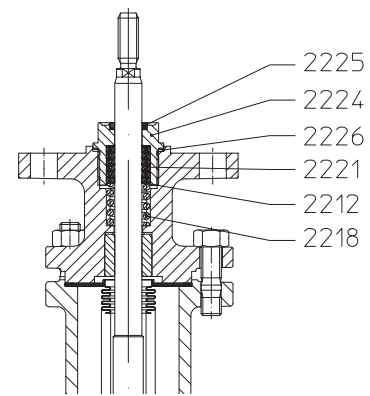
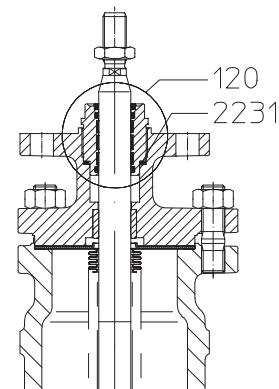

III. PTFE-packing / Pure graphite-packing

III. Stainless steel-bellows with V-ring unit

III. Stainless steel bellows seal with EPDM-sealing

Pos.	Sp.p.	Description	Fig. 32.471...90 / Fig. 35.471...90
1		Body	SA 216 WCB
2	x	Seat ring	SA 276 Gr.420
3	x	Plug	SA 276 Gr.420
4	x	Clamping sleeve	A2
8	x	Gasket	Pure graphite (CrNi laminated with graphite)
9		Stud	SA 193 B7
10		Hexagon nuts	SA 194 2H
2201		Bellows housing	SA 216 WCB
2202		Mounting bonnet	SA 216 WCB
2203	x	Stem- / Bellows unit	SA 276 Gr.420 / SA 240 Gr.321
2204		Guide bushing	SA 276 Gr.420 (hardened)
2205		Guide bushing	SA 276 Gr.420 (hardened)
2206	x	Gasket	Pure graphite (CrNi laminated with graphite)
2207		Stud	SA 193 B7
2208		Hexagon nuts	SA 194 2H
2210	x	Packing ring	Pure graphite
2212	x	Washer	SA 240 Gr. 304
2217	x	Coupling	AISI 303
2218		Compression spring	AISI301
2212	Set: refer to Pos. 100	Washer	SA240Gr.304
2221		V-ring unit	PTFE
2224		Coupling	AISI303
2225		Scraper	PTFE
2226		Gasket	SA479Gr.316Ti
2231	x	Gasket	Cu

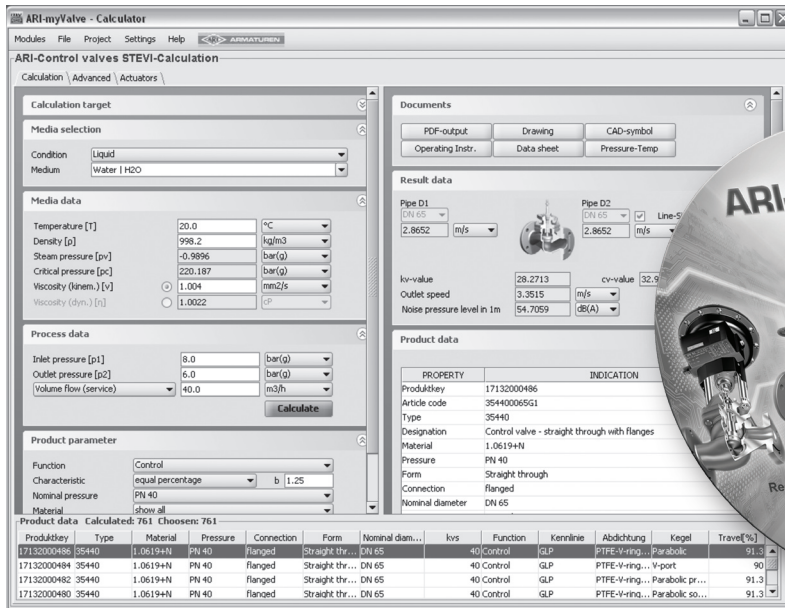
Stem sealings Fig. 471...90			
2010	x	Packing ring	Pure graphite
2010	x	Packing ring	PTFE
100	x	V-ring unit (set)	Set of: Pos. 2218 - 2226
120	x	EPDM-sealing, cpl.	EPDM / AISI303
		L Spare parts	

myValve® - Your Valve Sizing-Program.

myValve® is a powerful software tool that not only helps you size your system components; it also gives you instant access to all other data about the selected product, such as order information, spare parts drawings, operating instructions, data sheets, etc., whenever you need it.



Contents:

Module ARI-control valves STEVI-calculation

- Sizing (calculation of flow quantity Kv, volume flow Q, pressure drop Δp , sound level and selecting the valve.)

Media:

Integrated media-data bank (more than 160 media) with conditions:

- Vapours / gases
- Steam (saturated and superheated)
- Liquids

Special features:

- Project administration of the calculation and product data incl. spare part drawings concerning to project and tag number.
- Direct output or calculation and product data in PDF format.
- Product data could be taken for a direct order.
- SI- and ANSI-units with direct conversion to another data bank.
- Settings with over pressure or absolute pressure.
- All ARI valves are integrated in a data bank.
- Direct access concerning to the product on data sheets, operating instructions, pressure-temperature-diagram and spare part drawings
- Operation in company networks possible (no complex installations on individually PC's necessary).
- Extensive catalogue extending over several product groups.

System Requirements:

Windows operating systems, Linux, etc.



Technology for the Future.
GERMAN QUALITY VALVES

ARI-Armaturen Albert Richter GmbH & Co. KG, D-33756 Schloß Holte-Stukenbrock,
Tel. +49 52 07 / 994-0, Telefax +49 52 07 / 994-158 or 159 Internet: <http://www.ari-armaturen.com> E-mail: info.vertrieb@ari-armaturen.com